

Question block created by wizard

1. What is "rotor brake"?
 - a. A brake system used to stop the rotor blades from spinning on ground when the engine is shut down.
 - b. A brake used to control the rotor speed in flight and prevent the rotor from overspeeding.
 - c. A manoeuvre used to slow down the helicopter in a descent using the rotor as an air brake.

2. What effect does gyroscopic precession have on a helicopter?
 - a. The helicopter rotor blades reach maximum deflection approximately 90° later in the plane of rotation.
 - b. The helicopter tends to turn in the direction of the spinning rotor when in level flight
 - c. The helicopter tends to spin around its vertical axis

3. What effect will the movement of the collective control stick have?
 - a. Increase the pitch angle of the advancing main rotor blade and decrease the pitch angle of the retreating main rotor blade
 - b. Change the tail rotor blades pitch angle
 - c. change the pitch angle of all the main rotor blades simultaneously

4. The airspeed indicator in the figure has an indicated line at 105 knots, shown by the arrow. What is this indicated line?
 - a. the maximum airspeed. Higher than this speed may cause blade stall.
 - b. the maximum airspeed. Higher than this speed may cause structural damage.
 - c. the maximum ground speed for landing.



- a. the maximum airspeed. Higher than this speed may cause blade stall.
- b. the maximum airspeed. Higher than this speed may cause structural damage.
- c. the maximum ground speed for landing.

5. How does the main rotor blade react to the Coriolis effect when it flaps up?
 - a. The blade speeds up.
 - b. It increases its pitch angle.
 - c. The blade slows down.

6. At the end of an autorotation just before landing, how is the forward speed reduced?
 - a. By applying collective pitch.
 - b. By moving the cyclic stick aft.
 - c. By moving the cyclic stick forward.

7. At what altitude is ground effect most effective?
 - a. An altitude being $2 * \text{the rotor diameter}$.
 - b. An altitude being $1/2 * \text{the rotor diameter}$.
 - c. 25 feet.

8. What is the purpose of the horizontal stabilizer installed on some helicopters?
 - a. dampen out oscillations caused by the main rotor down wash
 - b. keep the tail up in cruise flight
 - c. keep the tail down in cruise flight

9. When a collective input is made, which of the following is correct?
 - a. the rotor will speed up
 - b. the helicopter will bank
 - c. more engine power is required

10. What is special about the bearings used in swashplates?
 - a. There are 2 or more sets of bearings used in conjunction together.
 - b. Do not change.
 - c. They are 2 bearings in 2 housings.

11. Because of high usage, what do the rod-end bearings need to be inspected for?
 - a. Corrosion
 - b. Axial play
 - c. Radial movement

12. Which anti-torque system used the coanda effect?

- a. Fenestron
- b. Delta 3 hinge
- c. NOTAR

13. Which type of main rotor does not have horizontal or vertical hinge pins and is able to teeter?

- a. semi-rigid rotor
- b. hingeless rotor
- c. fully articulated rotor

14. What is the purpose of the hydraulic fluid in a hydraulic damper?

- a. Cool and lubricate the damper.
- b. Cushion the movement of the damper.
- c. Reduction of vibrations.

15. Which of the following statements is correct?

- a. Main rotor blades can have a negative twist to obtain a more even distribution of lift
- b. Main rotor blades can have a negative twist to make the blades usable at higher airspeeds
- c. Main rotor blade can have a positive twist to balance out blade loads

16. What is not a function of the force gradient spring?

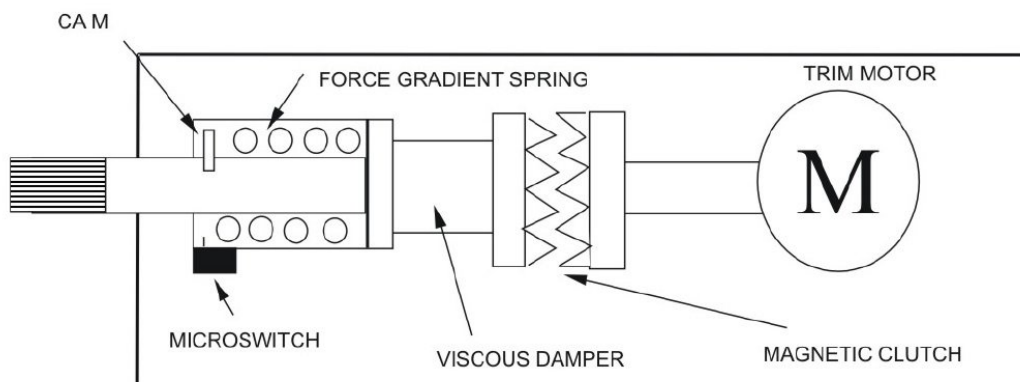

- a. Provide artificial feel.
- b. Return the controls back to the neutral position.
- c. Allow the magnetic clutch to be overridden.

17. Which flight control system requires the least maintenance time?

- a. fly-by-wire
- b. control rods
- c. hydraulic

18. What is indicated in the figure?

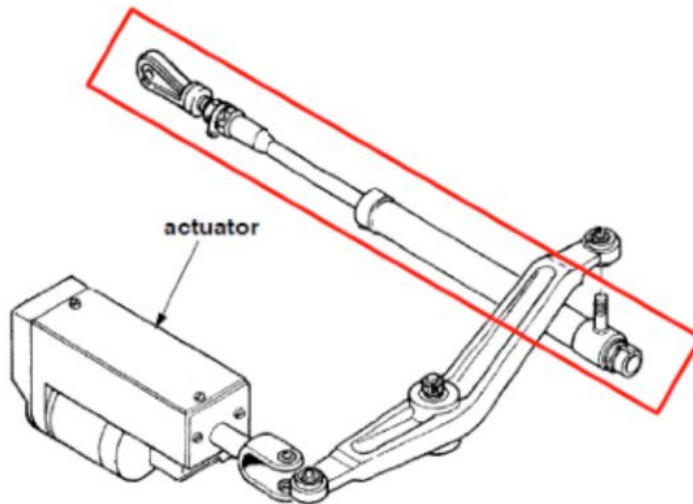

- a. Spring rod
- b. Control rod
- c. Alternate hydraulic actuator

19. The reason for flight control rigging is:

- a. to set the flight controls back to their correct position
- b. both answer A and B are correct
- c. to compensate for the wear of components like bearings and bolts

20. The blade sweeping of main rotor blades is applicable to:

- a. All types of main rotor.
- b. Semi rigid main rotors.
- c. Fully articulated main rotors.

21. A main rotor with pitch links attached to the leading edge has to be adjusted so that the blades fly higher. Which adjustment must be made?

- a. The weight of the blades must be increased by adding extra balance weights to the tips.
- b. The pitch links must be shortened.
- c. The pitch links must be lengthened.

22. The device shown, is used for?

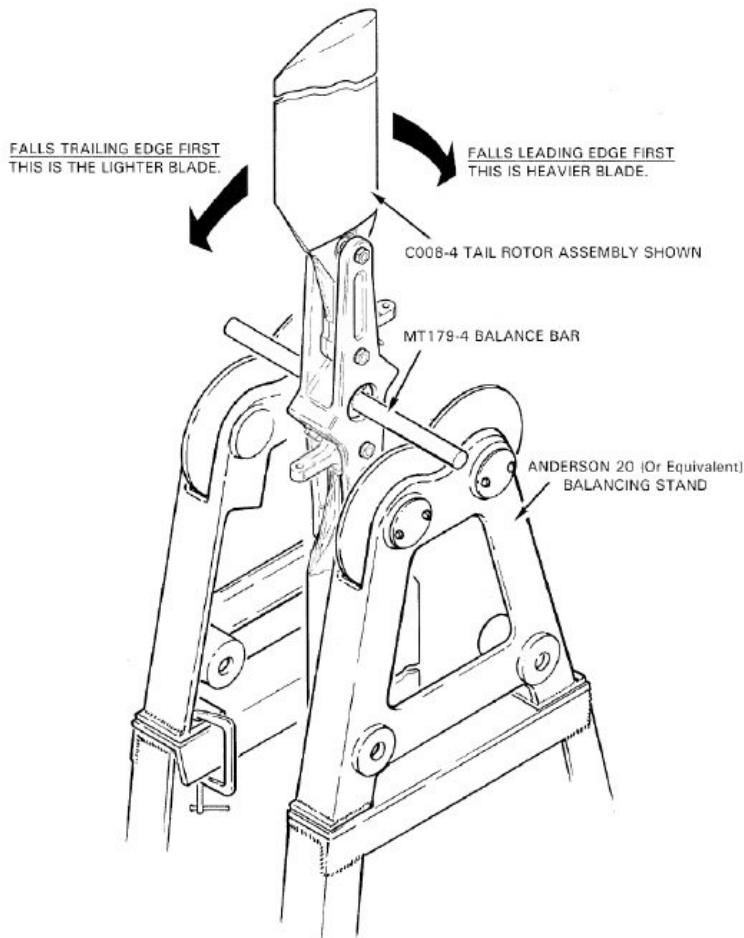

- Tail rotor static chord balance.
- Tail rotor dynamic balance.
- Tail rotor axial balance.

23. Which type of vibration would be associated with tail rotor?

- High frequency vibration.
- Low frequency vibration.
- Harmonic vibration.

24. In which phase of flight would blade vortex interaction be minimal?

- Medium speed flight.
- Low speed transition.
- High speed flight.

- 25.** A helicopter makes a hard landing and goes into ground resonance. What can the pilot do to stop it?
- a. Increase rotor speed.
 - b. Take off again.
 - c. Use cyclic input to try and act opposite to the resonance.

- 26.** Name the components in the figure.

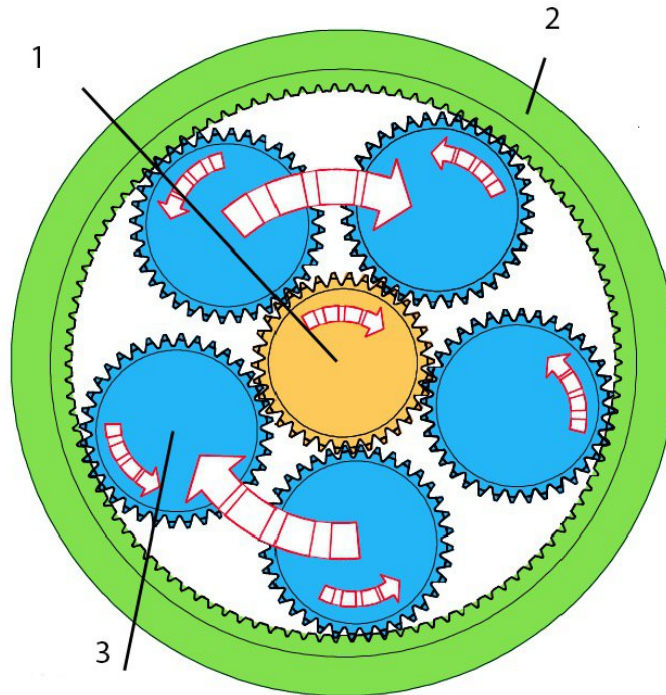

- a. 1= Ring gear,
2= Sun gear,
3= Planet gear
 - b. 1= Center gear,
2= Perimeter gear,
3= Orbital gear
 - c. 1= Sun gear,
2= Ring gear,
3= Planet gear
- 27.** What is the danger with a helicopter with a belt drive clutch?
- a. Danger of overspeeding the engine when disengaging the clutch.
 - b. Danger of overheating the clutch during engagement.
 - c. Danger of overspeeding the engine during clutch engagement

- 28.** How can the rotor brake be used to prevent "Blade sailing"?
- By keeping the rotor brake engaged during start up to pre-load the gearbox
 - By applying the rotor brake immediately after engine shut down
 - By keeping the rotor brake engaged to prevent it from spinning due to the wind
- 29.** Which part of the drive system will have a freewheel unit fitted?
- Engine drive shaft.
 - Tail rotor drive shaft.
 - Oil cooler.
- 30.** The canopy on most helicopters is categorized as?
- Primary structure
 - Auxiliary structure
 - Secondary structure
- 31.** Identify lines 1 and 2 in the figure.

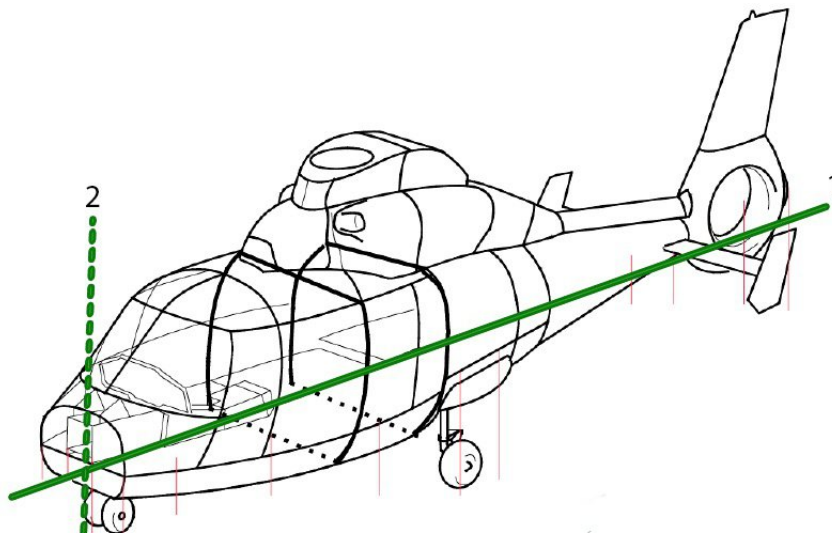

- 1 buttock lines; 2 waterlines
 - 1 waterlines; 2 body stations.
 - 1 body stations; 2 buttock lines
- 32.** What kind of stress is a rivet subjected to during installation?
- Shear
 - Hoop
 - Compression

- 33.** What is the main reason of having drains in the aircraft structure?
- The humidity caused by the fluid can influence the air-conditioning system.
 - Collecting fluids without draining could cause fire, corrosion or causing short cuts in the electrical system.
 - To avoid the extra weight. This can overload the structure.
- 34.** How are carbon fibre parts protected from lightning strikes?
- Aluminium lightning strike protection built into the carbon fibre parts.
 - Steel bonding jumpers between the carbon fibre part and the structure.
 - Carbon fibre parts do not need lightning strike protection because of its good electrical conductivity properties.
- 35.** "Which techniques may be used to attach a stringer to the skin? 1= Rivetting 2= Bonding 3= Welding 4= Nuts and bolts"
- 1,2 and 4
 - 1,2 and 3
 - 1 and 2
- 36.** How is the tailboom attached to the main fuselage on most civilian helicopters?
- Bolted
 - Riveted
 - Hinged
- 37.** Some cargo doors are fitted with gas spring rods. What are they used for?
- To keep the door in open position
 - To jettison the door when the emergency release is activated
 - To keep the door in closed position
- 38.** What is the benefit of troop seats?
- They provide more cargo space when folded up
 - They provide more comfort
 - They can carry more weight

39. What is the purpose of the drain plug shown in the figure?

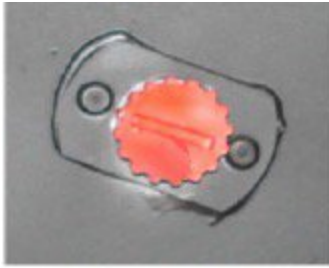

Drain plug

- a. To drain out any water which has collected in the compartment where the fuel tank is located.
 - b. To drain out any fuel which has collected the compartment where the fuel tank is located.
 - c. To allow the compartment to be inspected internally without removing the fuel tank.
40. What is commonly used in the engine mounting system to allow for misalignment of the main gear box and engine?
- a. Gimbal joint
 - b. Adjustable engine supports.
 - c. Elastomeric couplings.

41. Which of the three illustrated nuts is a tinnerman nut?

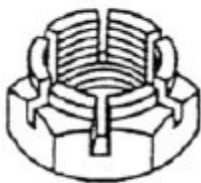

1



2



3

- a. 1
 - b. 2
 - c. 3
42. What is the most important surface protection for aluminium?
- a. Electro-plating.
 - b. Anodizing.
 - c. Tinning.

43. In a basic environmental control system like the figure, what is (are) the primary source(s) of air?

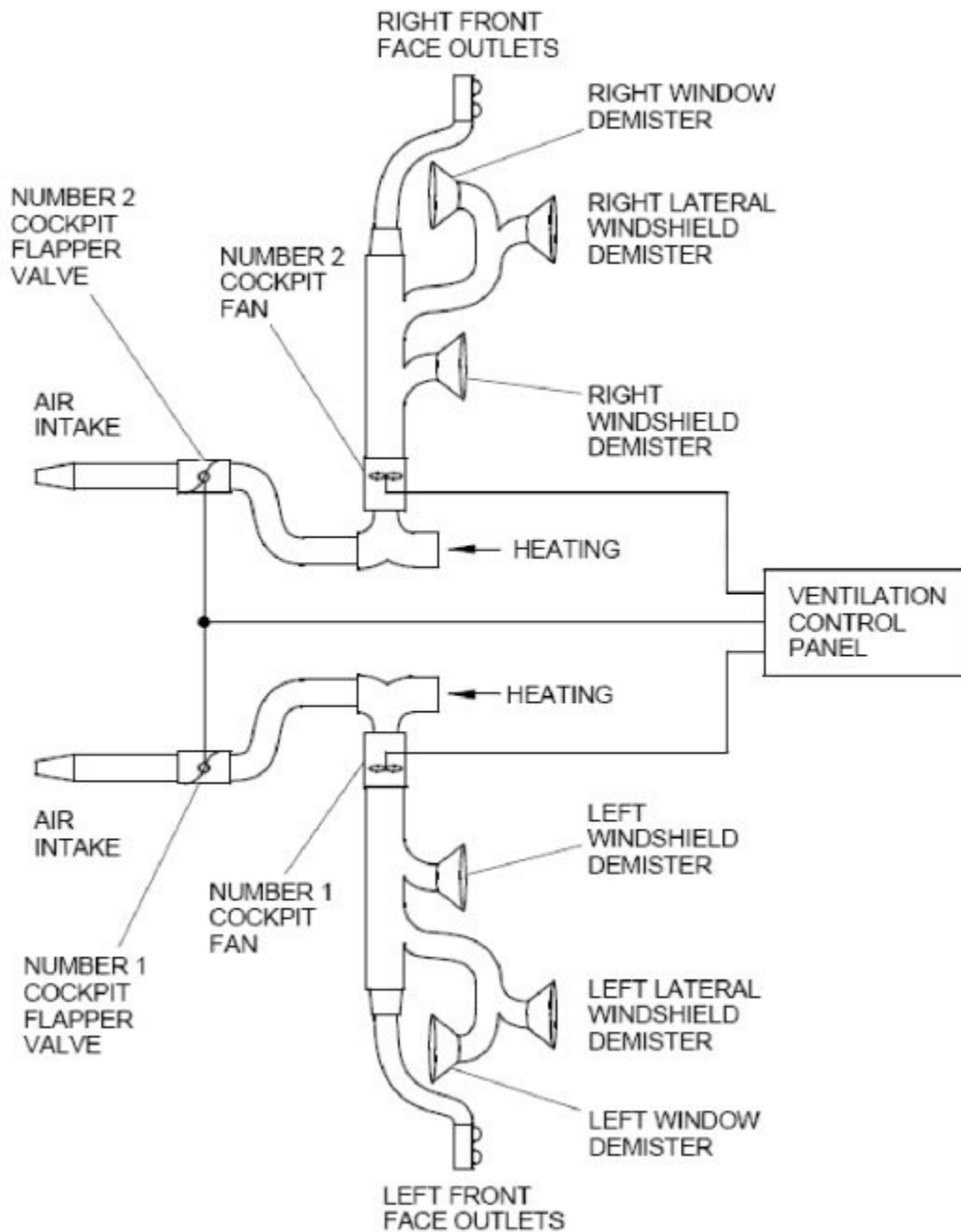

- a. Engine bleed air
- b. RAM air and engine bleed air
- c. RAM air

44. Which of the following air conditioning systems is considered to be the most simple system?

- a. Compressor
- b. RAM air

c. Engine bleed air

45. What happens to the refrigerant in a vapor cycle system when it goes through the expansion valve?

- a. The mixing with air with a high humidity causes its pressure to drop
- b. It undergoes an abrupt reduction in pressure which causes its temperature to drop.
- c. It changes from a vapor to a liquid, which causes a temperature drop

46. What is the purpose of recirculation air in the ventilation system?

- a. To increase the volume of air going into the cabin.
- b. To reduce the amount of bleed air taken from the engines to warm up the air going into the cabin.
- c. To control the humidity of the air going into the cabin.

47. What is the purpose of the venturi duct (jet pump) in the heating system?

- a. Extract cold air from the cabin
- b. Mix cold cabin air with hot bleed air from the engine
- c. Mix ambient air with hot bleed air from the engine

48. Using the schematic in the figure, the P3 electro valve will be commanded open when both engines are running, HEAT is selected ON and:

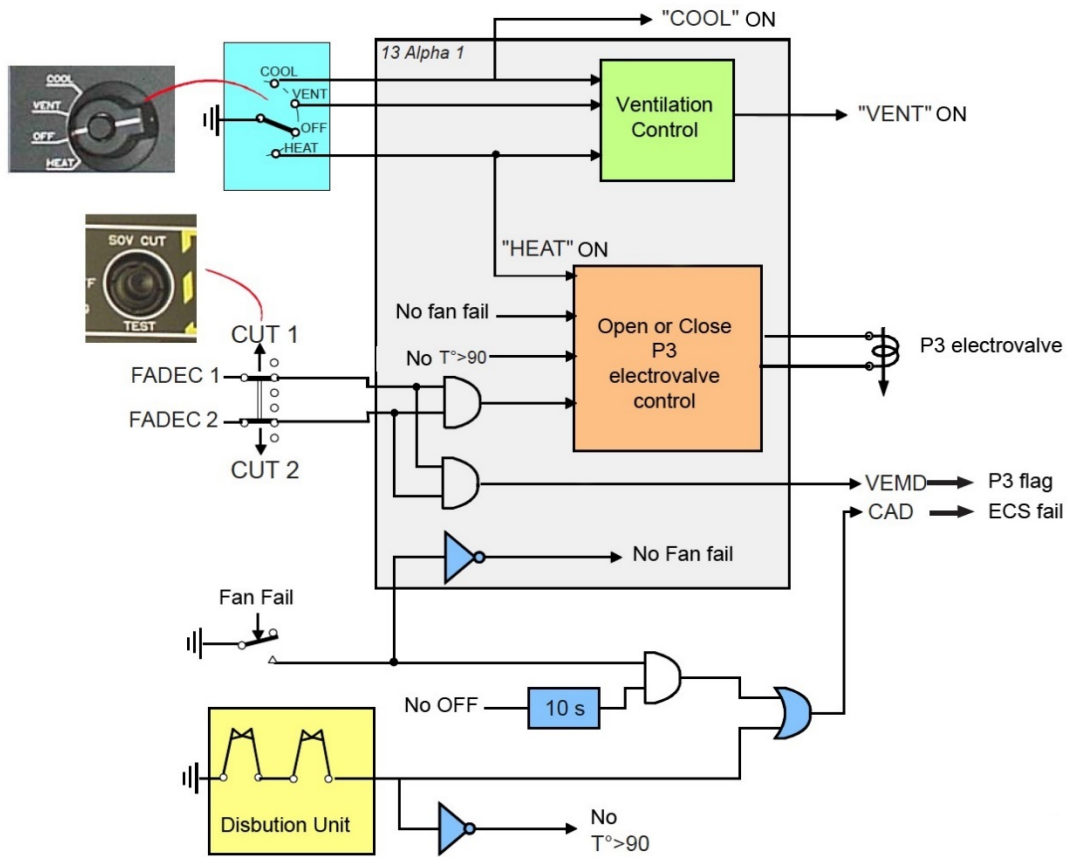

- The fan is not running and the temperature in the duct is more than 90 degrees
- The fan is running and the temperature in the duct is more than 90 degrees
- The fan is running and the temperature in the duct is less than 90 degrees

49. What air data instrument is represented in the figure?

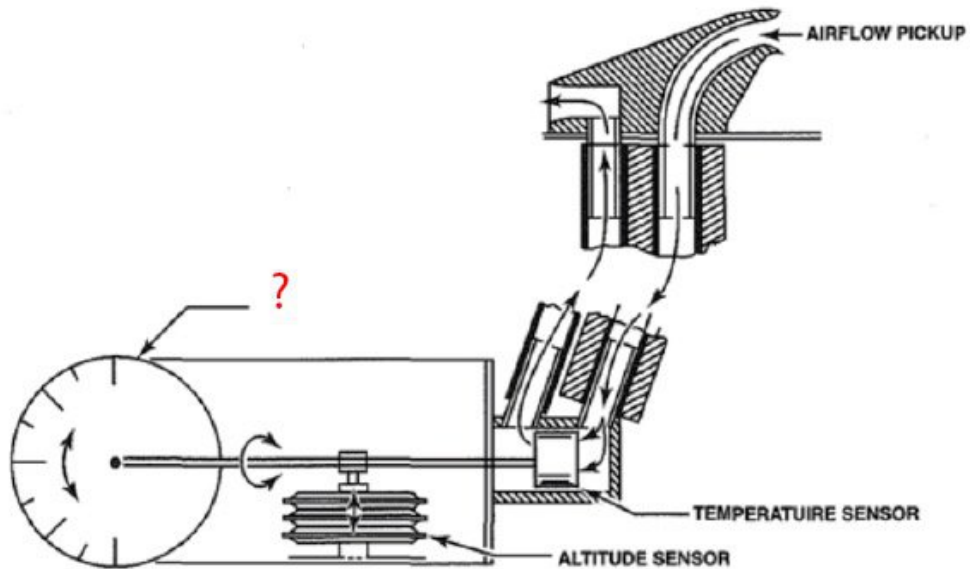

- a. Vertical speed indicator
- b. True air speed indicator
- c. Air speed indicator

50. What type of gyro would you find in an gyro horizon unit (artificial horizon)?

- a. Displacement gyro
- b. Vertical gyro
- c. Free gyro

51. Which of the following is NOT a dipping error?

- a. Deviation error
- b. Acceleration error
- c. Turning error

52. Which of the following statements about HUMS is true?

- a. HUMS is a on-demand system. It must be activated before it starts recording.
- b. HUMS is constantly recording and monitoring.
- c. HUMS is constantly monitoring and records when there is an abnormal situation.

53. On which electronic flight instrument display can weather radar information be selected?

- a. Electronic attitude director indicator (EADI)
- b. Electronic horizontal situation indicator (EHSI)
- c. Vehicle monitoring display (VMD)

54. What type of instrument would be constructed this way?

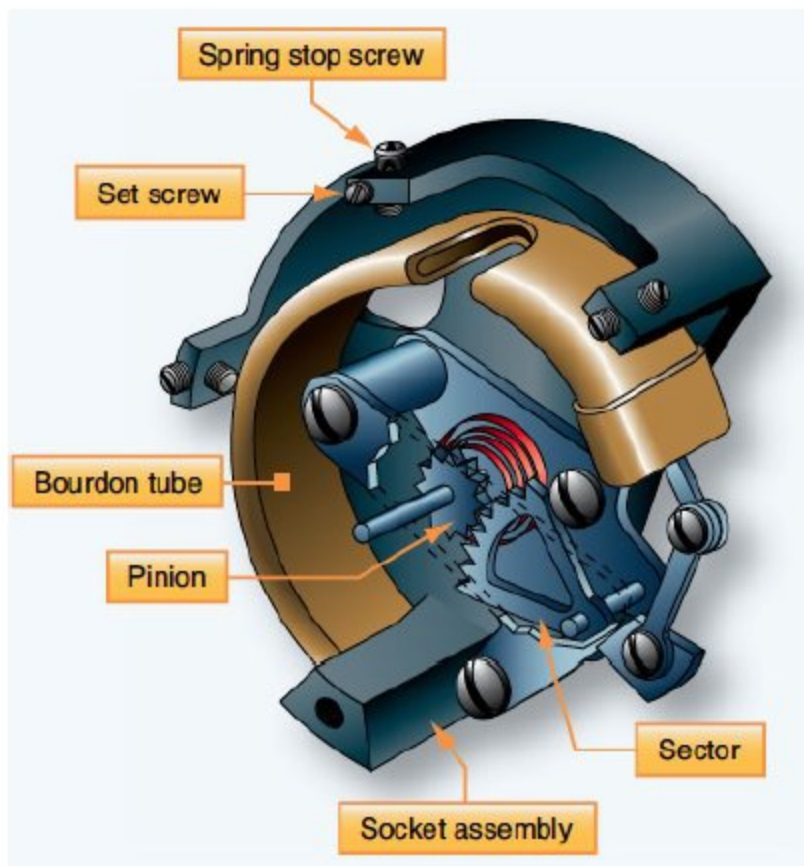

- a. Temperature gauge.
- b. Pressure gauge.
- c. Tachometer.

55. To provide the correct amount of rudder deflection to cancel the Dutch Roll is also called;

- a. yaw damping
- b. glide slope
- c. pitch trim

56. What is pitot pressure?

- a. It is the total pressure inside the aircraft.

- b. It is the outside air pressure at the instant of measuring.
 - c. It is the dynamic pressure of the air due to the forward motion of the aircraft.
- 57.** What system is used to transmit or receive automatically or manually generated reports or messages to or from a ground station?
- a. The SELCAL (Selective Calling) system.
 - b. The Multichannel Aviation Satellite Communication System (MCS SATCOM).
 - c. The Aircraft Communication Addressing and Reporting System (ACARS).
- 58.** Which communication system is used for long range communication?
- a. SELCAL
 - b. VHF
 - c. HF
- 59.** The three critical measurements for the air data computer are:
- a. Altitude, groundspeed and coordinates.
 - b. Airspeed, Altitude and temperature.
 - c. Airspeed, radio altitude and temperature.
- 60.** Modern aircraft weather antennas are?
- a. Flat plate antennas
 - b. Parabolic antennas
 - c. Blade antennas
- 61.** Why is "trickle charging" a NiCd battery not recommended?
- a. The battery life will be shortened
 - b. The battery cells may run dry due to the consumption of water
 - c. The battery may go into thermal runaway
- 62.** A lead-acid battery will be replaced by a NiCd battery. What must be done before the battery is installed?
- a. A battery temperature sensor must be installed
 - b. The battery compartment must be neutralized and flushed with water
 - c. A battery vent system must be installed

- 63.** In which type of generation system would you find a commutator?
- DC generator
 - AC generator
 - DC alternator
- 64.** What is the advantage of using an internal exciter (or Permanent Magnet Generator) in an AC alternator.
- More powerful alternator
 - No need for brushes
 - No need for a generator control unit (GCU)
- 65.** Which is the most commonly used emergency power generation system used on helicopters?
- Ram air turbine
 - Emergency battery power
 - Hydraulic motor generator
- 66.** What are the functions of a three-unit regulator?
- voltage regulation, current limiter, reverse current protection
 - differential voltage protection, over-voltage protection, parallel generator operation
 - voltage regulation, over-voltage protection, reverse current protection
- 67.** An aircraft has 2 engine driven generators which both power the entire electrical system. What type of bus system would be used?
- Split-parallel bus system
 - Parallel bus system
 - Split bus system
- 68.** What is the biggest negative aspect of an auto transformer?
- In case of an insulation failure, the primary voltage goes to the secondary coil
 - They are big and heavy
 - They create a large magnetic field which can interfere with sensitive systems
- 69.** In a basic DC external power system, how is applying reverse polarity to the aircraft electrical system prevented?
- By using an irreversible external power connector
 - By using different size pins in the external power connector

- c. By using a reverse polarity diode

70. What does increase the range on an emergency locator transmitter?

- a. Put it on the ground.
- b. Placing it on a flat piece of metal.
- c. Connecting it to the helicopters external antenna.

71. Which of the following statements is NOT true?

- a. The CPI is mandatory for helicopters operating in the oil and gas industry
- b. The CPI is a replacement for the Emergency locator transmitter (ELT)
- c. The Crash Position Indicator (CPI) system has a deployable beacon that floats

72. The operating mechanisms for emergency exits are:

- a. Standardized on large civilian helicopters only
- b. Standardized and the same for all helicopters
- c. Not standardized and different on most helicopters

73. What is the function of the manual control handle of the inertia reel shown in the figure?

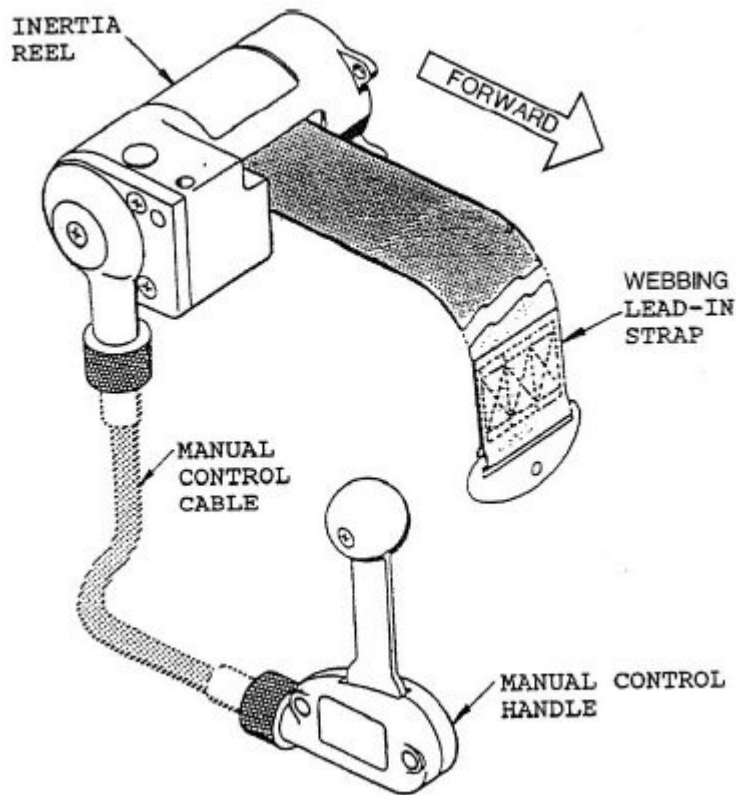

- a. To retract the lead-in strap
- b. To lock/unlock the reel
- c. To adjust the sensitivity of the inertia reel.

74. The cable of a rescue hoist is coloured orange on the first and last 20 feet. Why is that?

- a. To indicate that the operator has to use slow speed when the cable is in this coloured zone.
- b. To make the cable more visible to the operator
- c. To indicate to the operator that he is reaching the beginning or end of the cable

75. The emergency flotation gear is designed to:

- a. Stabilize the helicopters in the water
- b. Keep the helicopter afloat long enough for the passengers to escape
- c. Keep the helicopter afloat

76. How are seats secured?

- a. To the floor and/or ceiling

- b. To the floor only
- c. To the sidewalls

77. In the systron-donner sensor, what provides the overheat function of the sensor?

- a. Integrity switch
- b. Titanium wire
- c. Helium gas

78. In a dual loop configuration, LOOP 1 indicates a fire but LOOP 2 does not. The crew initiate a loop test with the following result: FIRE warning + LOOP 2 warning.

What component is faulty? Use the figure if necessary.

AFOLTS CONFIG	LOOP 1		LOOP 2		INDICATION	
	FIRE	FAULT	FIRE	FAULT	FIRE	STATUS AND MAINTENANCE MESSAGES
DUAL LOOP MODE	X		X		<input type="checkbox"/> X	<input type="checkbox"/> X 1
	X			X	<input type="checkbox"/> X	<input type="checkbox"/> X 1
		X	X		<input type="checkbox"/> X	<input type="checkbox"/> X 1
		X		X	<input type="checkbox"/> X	<input type="checkbox"/> X 1
	X					<input type="checkbox"/> X
			X			<input type="checkbox"/> X
		X				<input type="checkbox"/> X
				X		<input type="checkbox"/> X

- a. LOOP 2 is faulty.
- b. The fire test system is faulty
- c. LOOP 1 is faulty

79. Concerning fire extinguishing, what does a red disk on the side of the fuselage indicate?

- a. When the disk is missing, it indicates that the bottle has had a thermal discharge
- b. Indicates that the bottle nitrogen pressure is low and needs to be serviced
- c. When the disk is missing, it indicates that the firebottle has been fired

80. If a fire bottle has no pressure indicator, what must be done to determine if the pressure inside is still good?

- a. The bottle must be weighed and compared to a chart in the maintenance manual.

- b. The bottle must be submerged in water to see if there are any leaks. If not, the bottle is serviceable.
- c. This can only be done by the repair shop so the bottle must be replaced

81. Where does a helicopter generally store its fuel?

- a. Fuel tanks in the aft section
- b. In external fuel tanks
- c. Fuel tanks under the floor

82. Complete the figure.

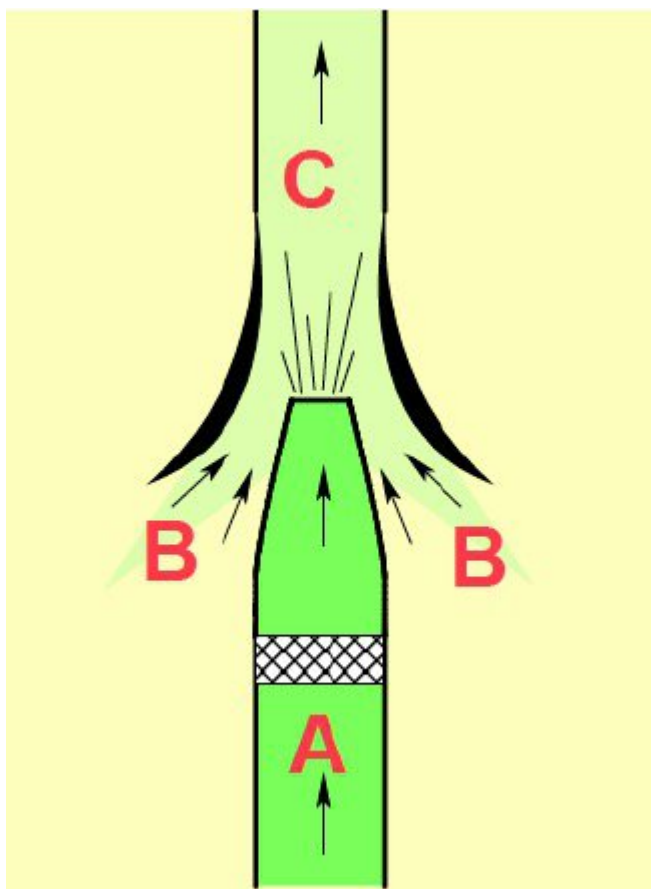

- a. "A = Mixed flow B = suction flow C = Motive flow"
- b. "A = Motive flow B = suction flow C = Mixed flow"
- c. "A = Suction flow B = Mixed flow C = Motive flow"

83. Which component in the fuel system is usually fitted in a canister?

- a. Fuel pressure switch
- b. Fuel shut-off valve
- c. Fuel pump

84. What is the purpose of the item shown in the figure?

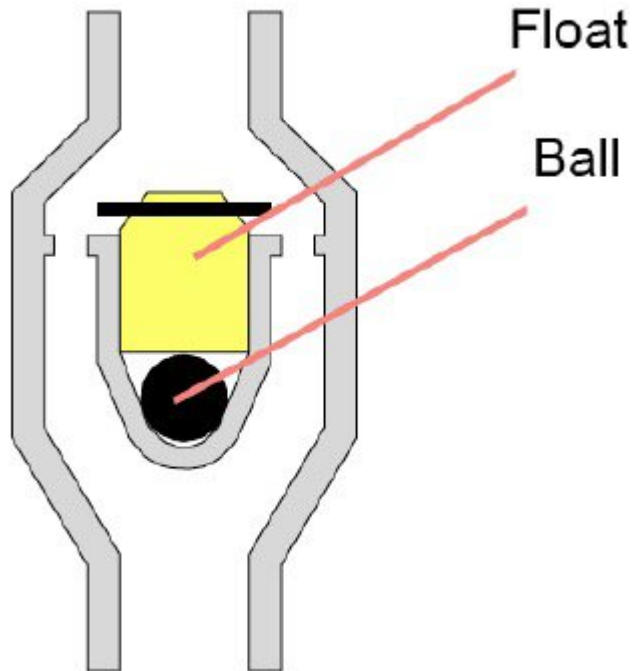

- a. Seal off the vent line in case the tank becomes pressurized
- b. Seal off the vent line and stop the fuel leaking out in case the helicopter rolls over
- c. Stop the fueling when the tank is full.

85. Which of the following statements concerning the fuel system is NOT true?

- a. Helicopters can be refueled via pressure refueling and gravity refueling
- b. All helicopters can be gravity refueled
- c. Helicopters with a single point refueling system cannot be suction defueled

86. In the figure, which diagram shows a closed center hydraulic system?

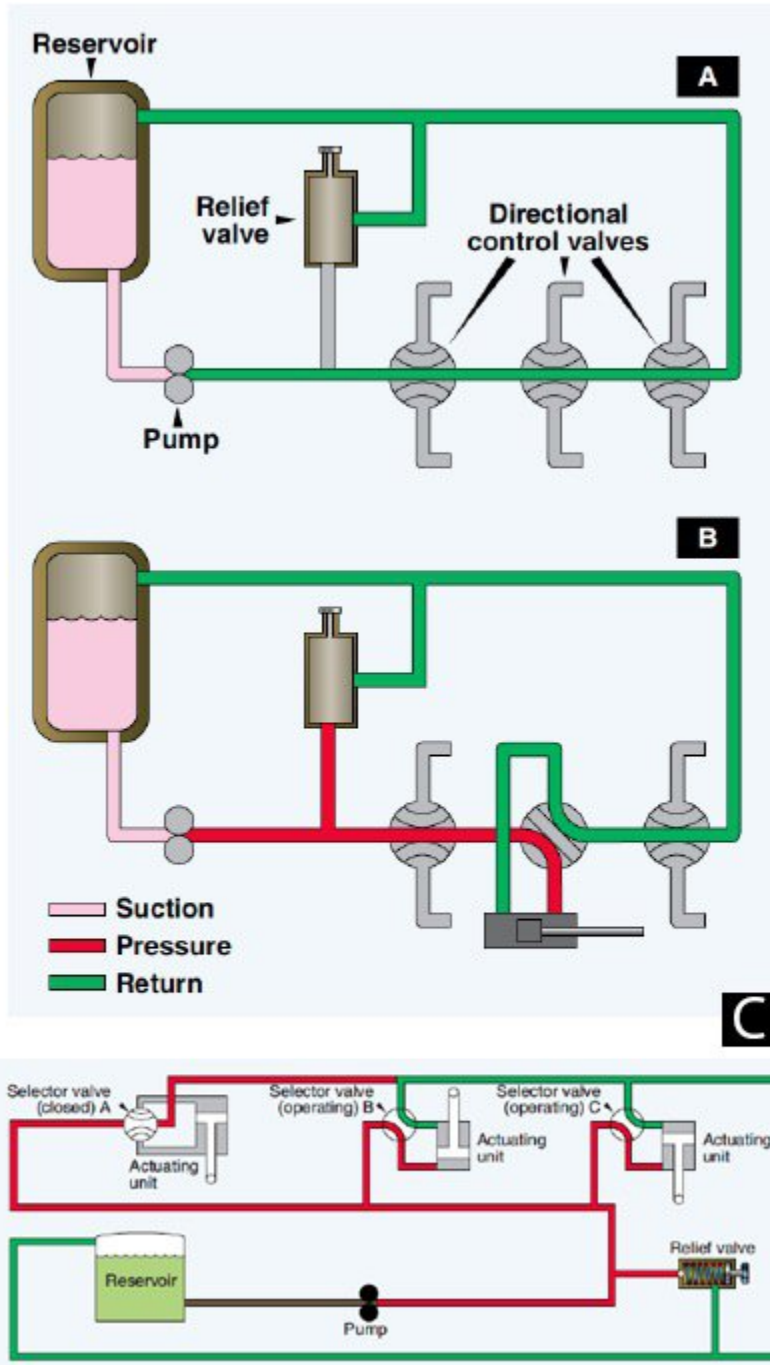

- a. A
- b. B
- c. C

87. What type of hydraulic fluid is used with synthetic rubber seals?

- a. Mineral based oil
- b. Vegetable based oil
- c. Synthetic ester based oil

88. What type of accumulator is shown in the figure?

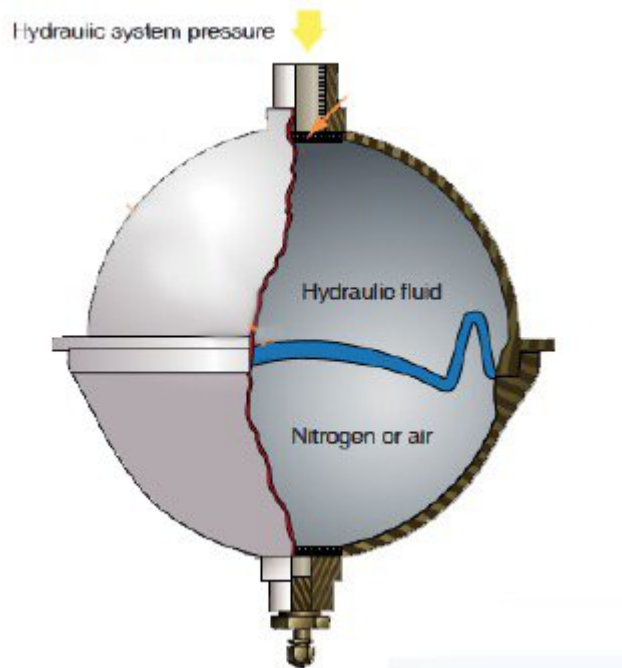

- a. Diaphragm type
- b. Hydraulic type
- c. Piston type

89. Which drawing in the figure shows the pump with the following properties: "Quiet in operation and supplies pressurized fluid in one direction irrespective of the direction of rotation."?

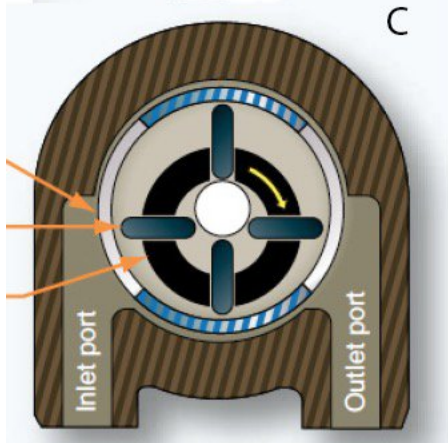
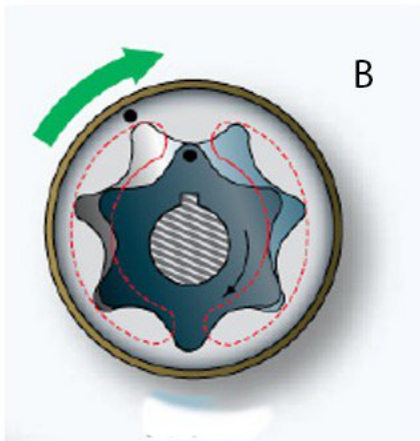
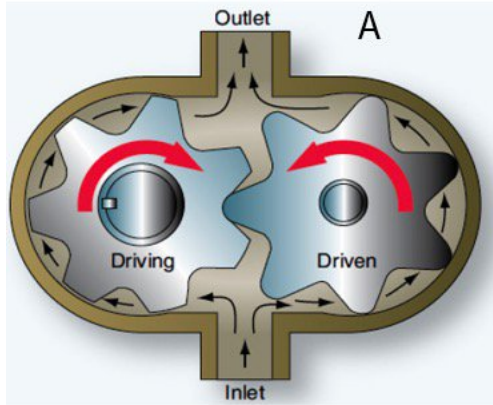

- a. A
- b. B
- c. C

90. Which of the following is NOT a function of the emergency hydraulic system powered by an electric pump?
- a. Retracting the landing gear.
 - b. Pressurizing the main and tail rotor flight control actuators for testing on ground
 - c. Pressurizing the parking brake
91. Where would you typically find a high pressure filter in a hydraulic circuit?
- a. Between the reservoir and the pump in the pump supply line
 - b. In the reservoir return line
 - c. Behind the pump in the pressure line
92. What device is shown in the figure?

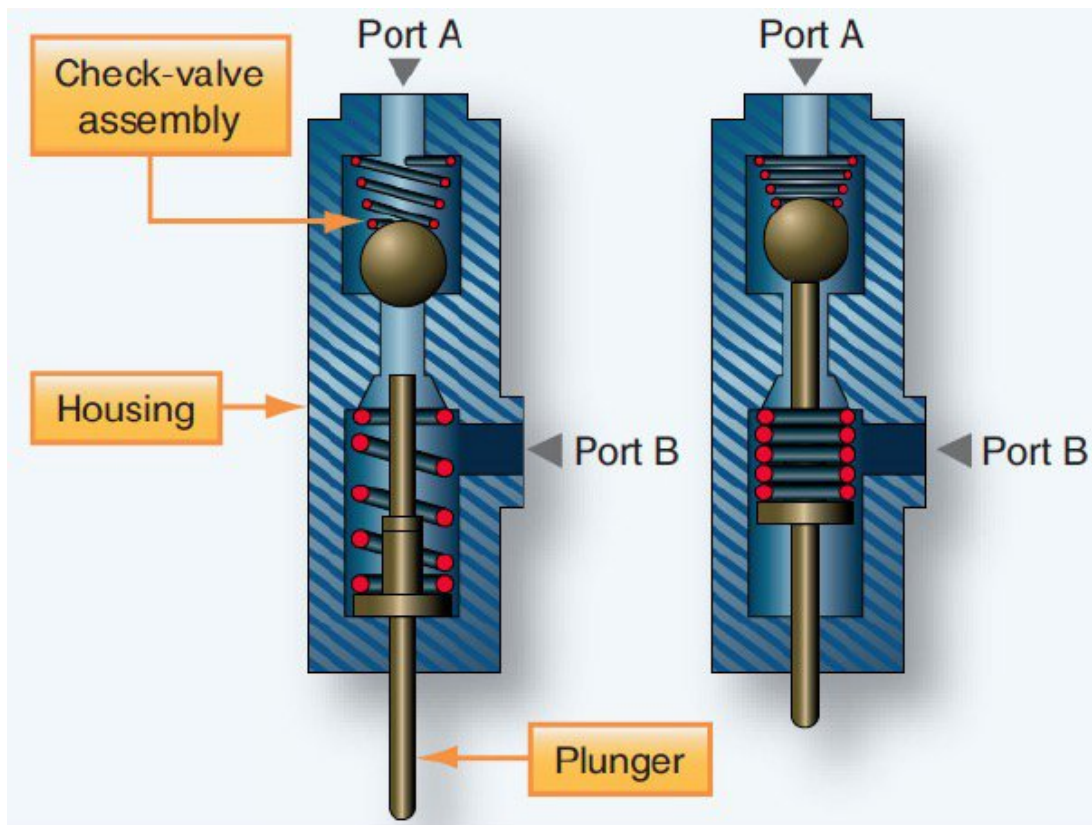

- a. Mechanical sequence valve
 - b. Hydraulic sequence valve
 - c. Check valve
93. What type of piston is generally used to lower and raise the landing gear?
- a. double acting balanced actuator
 - b. double acting unbalanced actuator

- c. single acting actuator

94. When will a hydraulic accumulator pressure indicator show the system pressure?

- a. When the hydraulic pumps are running
- b. When the accumulator is correctly charged with nitrogen
- c. When the hydraulic pumps are off

95. What precaution must be made when de-icing or anti-icing a helicopter?

- a. The correct fluid must be used to prevent adversely affecting the paint and windows
- b. The fluid must not stay on the surface of the fuselage too long to prevent corrosion
- c. The main and tail rotor blades must not come into contact with the fluid

96. Using the figure, what happens when ice is detected?

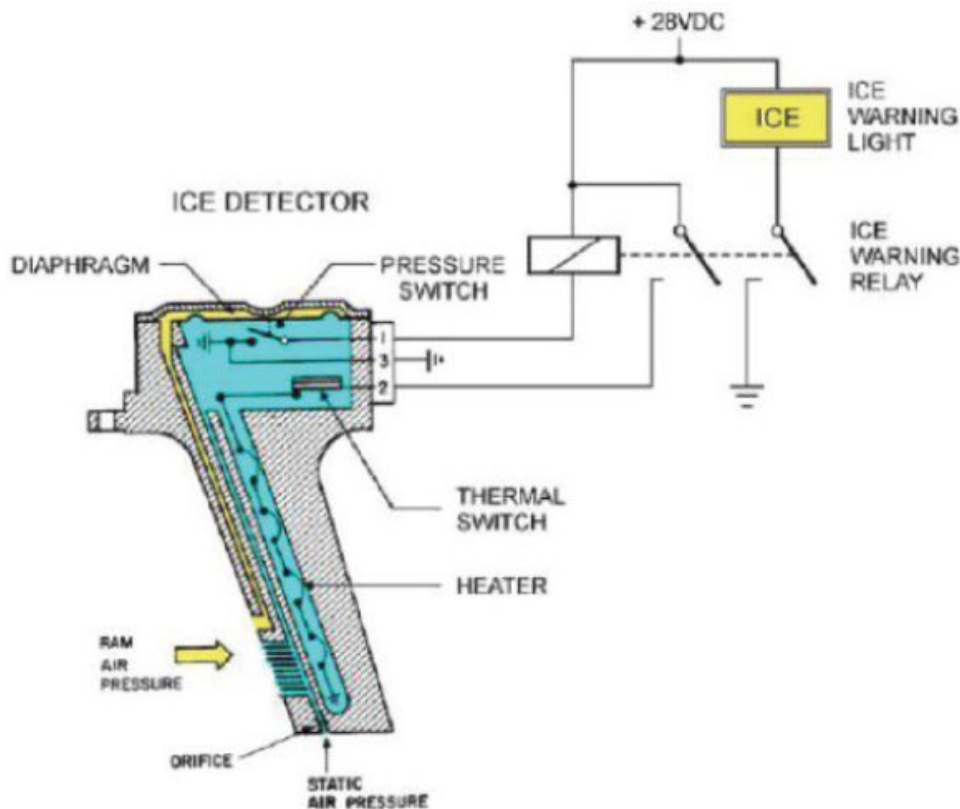

- a. The pressure switch opens due to the pressure difference in the diaphragm, closing the circuit and activating the ice warning relay. This in turn switches on the ICE warning light and the heater.
- b. The pressure switch closes due to the pressure difference in the diaphragm, closing the circuit and activating the ice warning relay. This in turn switches on the ICE warning light and the heater.

- c. The ice detector which is heated, cools down until the thermal switch activates and closes the circuit which turns on the ICE warning light

97. On an engine with bleed air anti-icing, what is used as the source of bleed air?

- a. The high pressure compressor of the other engine
- b. The high pressure compressor of the engine being anti-iced
- c. The high pressure turbine of the engine being anti-iced

98. Using the figure, which conditions must be fulfilled to make it possible to operate the rain repellent system?

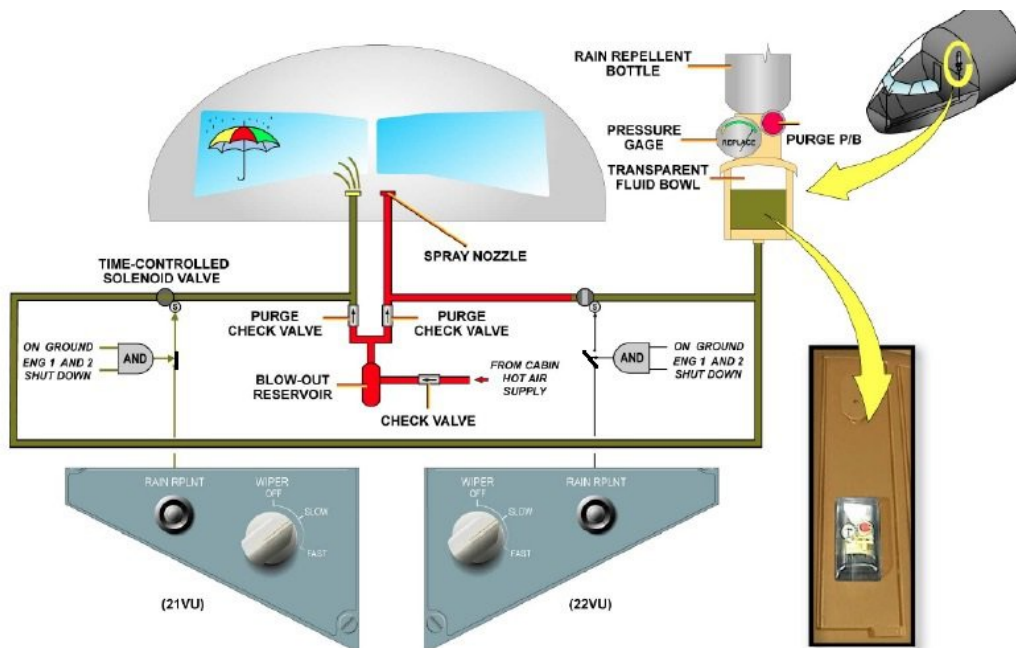

- a. Both engines running and aircraft in flight
- b. Both engines off and aircraft on the ground
- c. Both engines running or aircraft in flight

99. Probe heat system with a probe heat computer will operate automatically when?

- a. The electrical power is turned on
- b. The engines are off.
- c. The aircraft takes off

100. What is the purpose of the parallel motion device on a wiper system?

- a. Ensures the blade moves in arc.
- b. Ensures the blade maintains contact with the screen.

- c. Ensures the blade remains parallel with the screen.

101. What type of landing gear is shown in the figure?



- a. Semi-levered suspension
 - b. Levered suspension
 - c. Direct acting suspension
- 102.** A full strut servicing must be performed on a gas/oil oleo. Must the aircraft be placed on jacks.?
- a. No, the servicing can be done with the aircraft resting on its wheels
 - b. Yes, with the wheels clear off the ground
 - c. Yes, with the wheels touching the ground
- 103.** What are the possible methods used to up-lock the helicopter landing gear?
- a. Mechanical Up lock hook, Internal uplock mechanism, hydraulic lock
 - b. Mechanical uplock hook, overcentering device, internal lock
 - c. Hydraulic lock, external uplock mechanism, overcentering device

104. What is the function of switch K1901 in the figure?

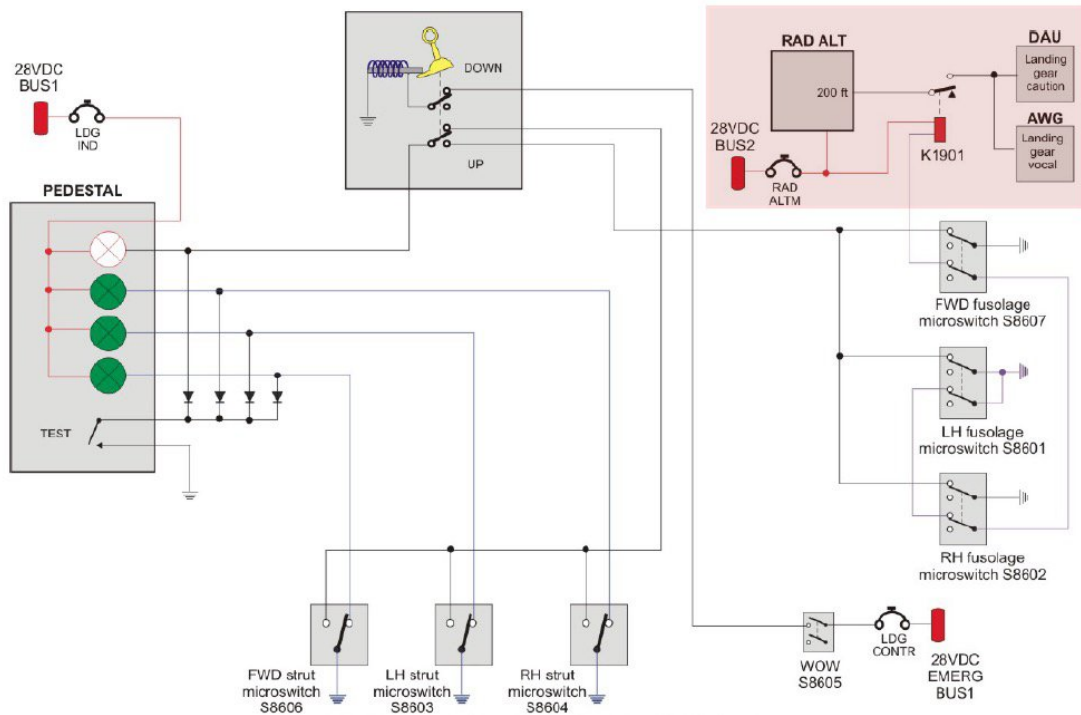

- If the aircraft descends below 200 feet the landing gear will be automatically extended.
- If the aircraft goes below 200 feet and the gear is retracted, a warning will be triggered.
- If landing gear is still extended above 200 feet a warning will sound

105. What is the cause of the wear on a tyre as can be seen in the figure?

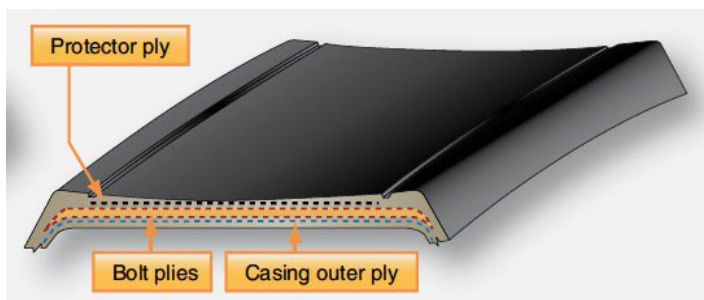

- Under inflation
- This is normal wear
- Over inflation

106. What is the advantage of the type of tyre shown in the figure?



- a. Provides better water dispersion and prevents aquaplaning
- b. Prevents shimmy
- c. Allows for operations on unhardened runways

107. Which of the following statements is true?

- a. All helicopters are fitted with a tail skid.
- b. Some helicopters have a movable tail skid.
- c. Tail skids are designed to protect the tail boom and tail rotors from impact with the ground during a flare manoeuvre.

108. What is shown in the figure?

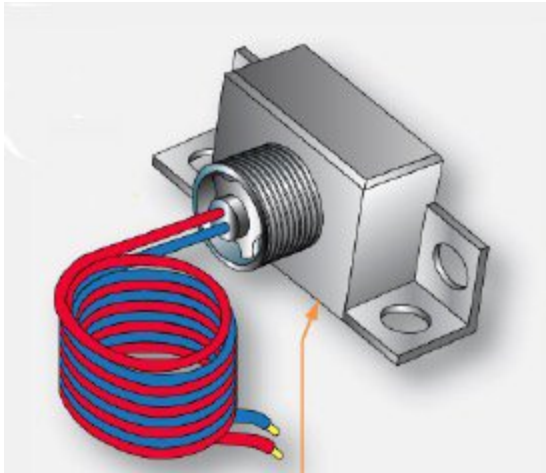

- a. A squat switch
- b. A proximity sensor
- c. A weight on wheel microswitch

109. What is NOT used as a shock absorber on a ski landing gear?

- a. Flexing of the crossbeams
- b. Coil spring cylinder
- c. Air/oil cylinder

110. Some helicopters have a "LITE" annunciator in the cockpit. What is the purpose of this annunciator (See the figure).

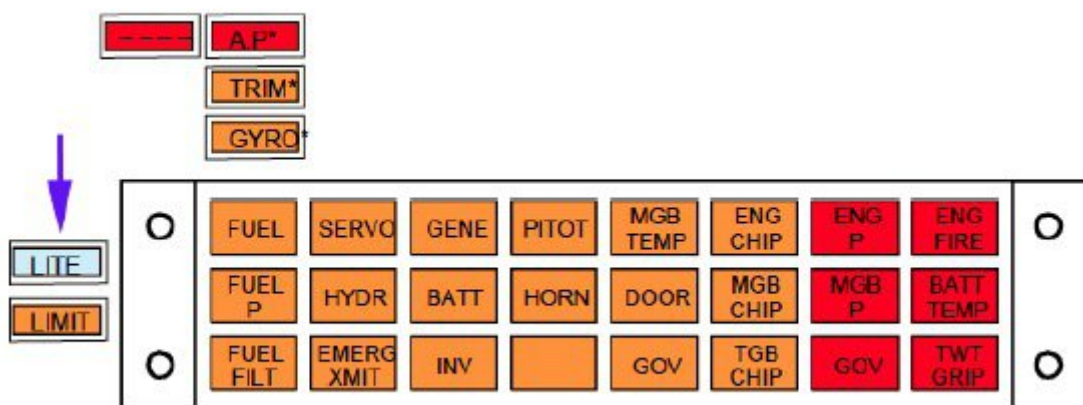

- a. It warns the pilot that the landing light is switched on
- b. It warns the pilot that the landing light has failed
- c. It warns the pilot that the landing light is extended

111. What type of light beam does a rotating reflector beacon emit?

- a. A narrow beam on one side and a spread beam on the other
- b. 2 narrow high intensity beams
- c. 2 spread light beams

112. On a flight deck spot light equipped with 2 switches and a rheostat, what are the function of the 2 switches?

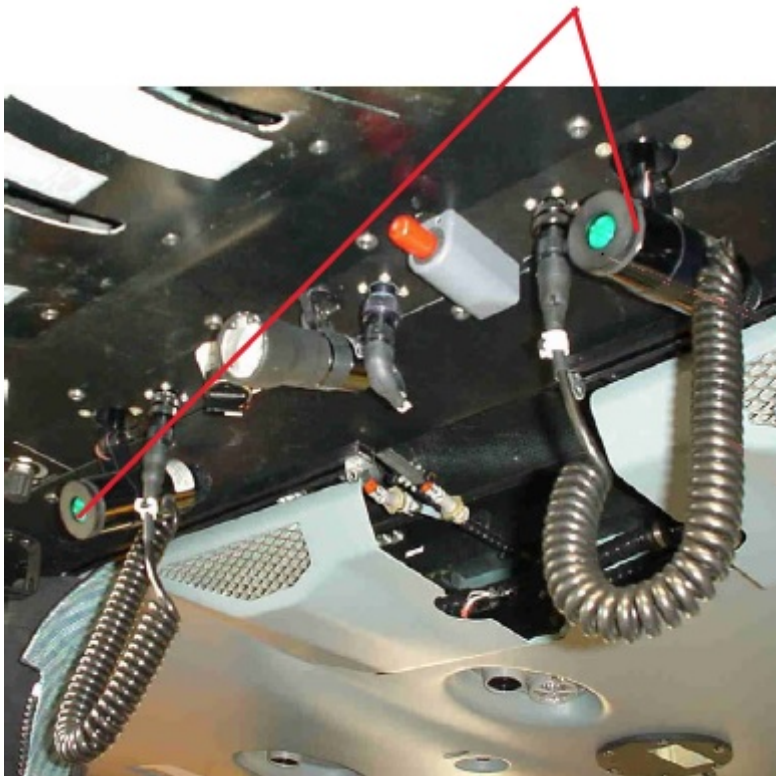

- a. One switch turns the light on, the other turns it off
- b. One switch turns the light on and is then controllable by the rheostat, the other switch turns the light off
- c. One switch turns the light on and is then controllable by the rheostat, the other switch turns the light on full bright

113. What powers the HEEL lights?

- a. Main battery
- b. Independent battery
- c. Main aircraft power

114. What type of seals are normally used for bleed ducts?

- a. Crush type seals

- b. Rubber O-rings
 - c. Teflon gaskets
- 115.** An air bottle pressure has dropped to less than 50 psi and must be recharged. What precautions must be taken?
- a. The bottle should be recharged in stages and let it cool down to prevent it getting too hot.
 - b. The bottle should be replaced and serviced in a dedicated shop.
 - c. The bottle should be recharged very slowly.
- 116.** What is done to protect bleed air ducts from the effects of Skydrol hydraulic oil?
- a. They have a protective cover
 - b. They are gold plated
 - c. They are made of titanium
- 117.** In a helicopter, what is bleed air mostly used for?
- a. Windscreen anti-icing
 - b. Engine starting
 - c. Cabin heating
- 118.** What is the function of an Airborn Computer Network
- a. A network that connects the aircraft management computer to all analoge computing units on board the aircraft.
 - b. A network that connects all relevant onboard computing units to each other.
 - c. A network that allows the transfer of data to and from the aircraft management computer to an external computer.
- 119.** How are software uploads to the aircraft management computer (AMC) performed?
- a. Via an optic fiber port in the AMC and a laptop
 - b. Via a data transfer device (DTD) to both AMCs
 - c. Directly into the computer via a card reader slot
- 120.** Integrated modular avionics (IMA) software is:
- a. Universal to all helicopters fitted with the same type of IMA
 - b. Always specific to each individual helicopter
 - c. Specific to type and model of helicopter

- 121.** How are computers connected with each other on a ARINC 664 network identified?
- Each computer has its own IP address
 - Each unit has a data label identifier
 - Each unit has an equipment ID number
- 122.** Which page in the Central maintenance system shows the actual flight control trim motor positions and the current condition of the control system?
- Synoptics page
 - Test status and results page
 - System diagnostics menu
- 123.** When data loading is performed to the FMS, what happens to the software that was uploaded?
- Is transferred to the applicable unit, updates it and the old data are stored as back-up.
 - Updates the applicable unit
 - Is transferred to the applicable unit, updates it and is stored in the unit as a backup
- 124.** What type of printer is generally used for the on board maintenance system?
- Matrix printer
 - Ink jet printer
 - Thermal printer
- 125.** In the HUMS system, when is an event recorded?
- Every time an exceedance occurs
 - Every time the pilot selects "event record"
 - Every change in flight condition (ground to hover, hover to climb,...)
- 126.** The Isolated Data Network (IDN) is displayed with red arrows. Which component belongs to this system?
- PES (Passenger Entertainment System).
 - IMA (Integrated Modular Avionics).
 - TWLU (Terminal Wireless Local area network Unit).
- 127.** A Class 3 electronic flight bag is:
- Integrated into the aircrafts avionics systems using the main multifunction displays
 - Fitted to the aircraft with independent displays

c. Portable unit

128. On a helicopter, which network can be accessed wireles?

- a. Isolated date network
- b. Open data network
- c. Both open and isolated data networks